



Hy-Lok

**Hydraulic Swaging Unit
Work Procedure**

Hydraulic Swaging Unit Work Procedure

STEP 1. Swaging Unit Preparation

- 1.1 Select the appropriate tube O.D. size jig & die.
- 1.2 Thread the jig & die into the swaging unit hand tight. Tighten slightly with the wrench supplied with the unit.
- 1.3 Install the fixing bolt and tighten slightly with the hex wrench supplied with the unit.

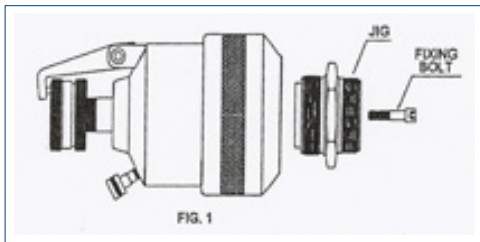

- 1.4 Connect the hydraulic pump to the swaging unit using the quick coupling adapter on the end of the hose and the swaging unit. (Fig. 2)

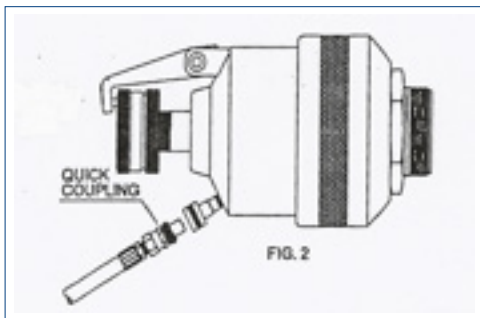

STEP 2. Nut & Ferrule Set Assembly

- 2.1** Prior to installing the nut and ferrules onto the swaging unit, make sure the ferrules are in the proper sequence and orientation. (Fig. 3)

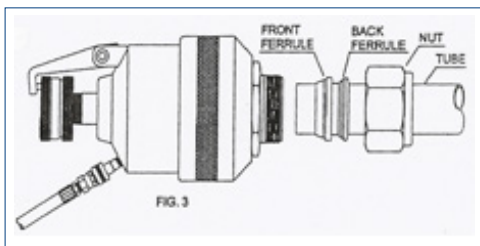

- 2.2** Hand-tighten the nut and ferrules onto the swaging unit
- 2.3** Insert the tubing into the nut and ferrules assembly. Make sure the tube bottoms and remains bottomed against the shoulder in the jig.
- 2.4** Close the valve on the hydraulic pump. While rotating the tube clockwise and counterclockwise keeping it against the shoulder in the jig, pump the handle slowly until there is resistance felt in rotating the tube. Stop pumping. (Fig. 4)

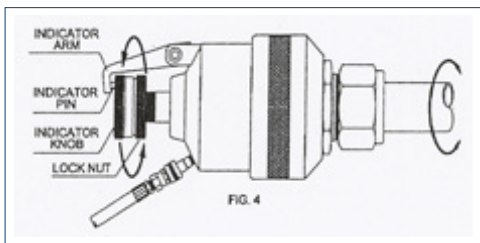

- 2.5** Observe the indicator arm. If the indicator arm is in position behind the indicator knob, rotate the indicator knob counterclockwise to insure it is snug against the indicator pin. (Fig. 4)
- 2.6** If the indicator arm is not in position behind the indicator knob, rotate the indicator knob clockwise until the indicator pin can be placed behind the indicator knob. Rotate the indicator knob counterclockwise to insure it is snug against the indicator pin. (Fig.4)

STEP 3. Swaging Procedure

3.1 Make sure the valve on the hydraulic pump is closed. Pump the handle until the indicator arm releases. (Fig. 5)

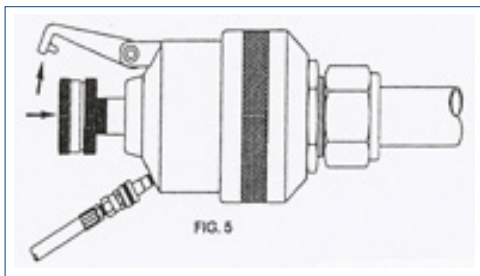

3.2 Open the valve on the pump to relieve the hydraulic pressure. Completely loosen the nut from the swaging unit and remove the tube with pre-swaged ferrules.

3.3 Inspect the swaging action. The front ferrule may be “loose”; meaning it may spin in a rotary motion on the tube and move slightly in an axial motion on the tube due to spring-back. The rear ferrule will be solidly swaged to the tube O.D.

3.4 To swage another connection, repeat Steps 2 and 3.



Hy-Lok USA, Inc.

14211 Westfair West Dr.
Houston, TX 77041, USA

Toll-Free // 888.300.5708

Phone // 832.634.2000

Fax // 832.634.2099

Website // www.hylokusa.com

Email // info@hylokusa.com